

(b) Consider two processes p1 and p2. Write the structure of process p1 to solve the critical section problem using Peterson's solution? Justify that progress requirement is satisfied in this solution.

(4+3)

(1000)

[This question paper contains 12 printed pages.]

Your Roll No.....

Sr. No. of Question Paper : 1565

G

Unique Paper Code : 2342012302

Name of the Paper : Operating Systems

Name of the Course : B.Sc. (H) (Computer Science)

Semester : III

Duration : 3 Hours

Maximum Marks : 90

Instructions for Candidates

1. Write your Roll No. on the top immediately on receipt of this question paper.
2. Question No. 1 (Section-A) is compulsory.
3. Attempt any **four** questions from **Section-B**.
4. Parts of a question should be attempted together.

(Section A)

1. (a) Briefly explain how an operating system provides efficiency to the system and convenience to the end user. (2)

P.T.O.

- (b) A bit, called the _____ bit, is added to the hardware of the computer to indicate the current mode: _____ (0) or _____ (1). (2)
- (c) For a given set of I/O requests, argue that C-LOOK algorithm will perform more efficiently than LOOK algorithm. (2)
- (d) List any two forms of user interface for an operating system? (2)
- (e) Consider the following resource allocation graph

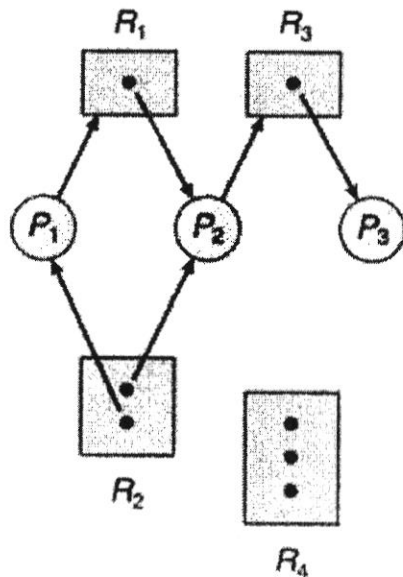

- (ii) Draw Gantt chart for Priority based (preemptive) algorithm and calculate waiting time for every process. (4+4)
- (b) Consider a demand paging system with the page table stored in memory. What should be the maximum page fault rate to achieve an effective access time of 200 nanoseconds if the time taken for a memory reference is 100 nanoseconds. Assume that a page fault is serviced in 10 ms. (2+3)
- (c) Which scheduler controls the degree of multiprogramming? How? (2)
- 7. (a) What are the four necessary conditions for deadlock to occur? For the following resource allocation graph, find if the system is in a deadlock state. Justify your answer. (4+4)

1565

10

(c) Identify any two advantages of a multiprogramming system over a single programming system?

(2)

(d) What is external fragmentation? Does contiguous memory organization scheme suffer from external fragmentation? Give arguments to support your answer.

(3+4)

6. (a) Consider the following set of processes, with the length of CPU burst time given in milliseconds:

Process	Arrival Time	Burst Time	Priority
P1	0	3	2
P2	2	5	1 (Highest)
P3	3	3	3
P4	5	1	4

(i) Draw Gantt chart for Shortest Job First algorithm and calculate turnaround time for every process.

1565

3

Identify the following :

(i) Processes

(ii) Resources

(ii) assignment and Request edges (3)

(f) Give any three differences between paging and segmentation schemes of memory management.

(3)

(g) Consider following statements executing processes P1 and P2:

P1 : counter++

P2 : counter--

(Assume that Initial value of counter=10.)

Discuss the problem that can occur due to race condition in concurrent execution of these processes?

(3)

P.T.O.

- (h) What is the Belady's anomaly in context of FIFO page replacement algorithm? (3)
- (i) Consider a file "f1.txt" in Unix system with permission bits 072 (in 3 octal system). For this file, find the access permissions allowed for owner, group and others. (3)
- (j) What will be the output of the given code segment? Briefly give reasons for your answer. (3)

```
int q = fork();  
  
if (q == 0)  
    cout<< "\n Inside the child";  
  
else  
{  
    wait (NULL);  
    cout<< "\n Inside the parent";  
}
```

- (b) Under what conditions the SCAN and C-SCAN algorithms perform better than other disk scheduling algorithms. (3)
- (c) Mention any three challenges that may be faced by a software developer in a multicore system. (3)
- (d) In a file system, path names for a file can be of two types: absolute and relative. Differentiate giving an appropriate example. (3)
5. (a) Consider a 40-bit logical address. Find the number of bits required to represent the page number and page offset fields. It is given that the page size is 4 KB. (4)
- (b) Modern operating systems are interrupt driven. Briefly explain how interrupts are signalled by the operating system. (2)

Process Number	Nature of Request	Amount of memory requested (in KB)
P0	Allocation	20
P1	Allocation	30
P2	Allocation	22
P0	Deallocation	
P1	Deallocation	
P3	Allocation	50
P4	Allocation	20

4. (a) For a given queue of I/O requests 98, 183, 37, 122, 14, 124, 65, 67 find total number of head movements using

(i) SCAN algorithm

(ii) C-SCAN algorithm

Assume that the head starts at 57 and starts moving towards left end. (6)

- (k) Differentiate between the following : (2+2)

(i) Data Parallelism and Task Parallelism

(ii) Turnaround Time and Waiting Time

(Section B)

2. (a) Under what condition will a child process become an orphan process? What is the role of init() process in the life cycle of an orphan process? (2+2)

- (b) Give any two reasons due to which a parent process may terminate the execution of one of its child processes? Explain the phenomenon of cascading termination with respect to parent and child processes. Under what condition(s) will a terminated child process be known as a zombie process. (2+2+1)

(c) Consider the following page reference string

3 0 1 7 5 7 6 4 7 2 2 7 0

Assume that three frames are available. All frames are initially empty. How many page faults would occur for the following algorithms? Show the steps.

(i) FCFS page replacement algorithm

(ii) Optimal page replacement algorithm

(3+3)

3. (a) Mention any one limitation each of Monolithic and Microkernel approaches of Operating System design? How can the modular approach overcome each of these limitations? (2+2)

(b) Consider the following segment table :

Segment	Base	Length
0	250	100
1	350	40
2	1345	350
3	1673	600

What are the physical addresses corresponding to the following logical addresses?

(i) 0, 120

(ii) 1, 25

(iii) 2, 140

(iv) 3, 329

(4)

(c) Suppose there is a system with 128KB of memory with no memory initially allocated. Given the following sequence of requests by the processes, show the memory layout at intermediate stages that is, after allocation/deallocation of memory for each process. Assume that the system uses a best-fit allocation algorithm. (7)